

Series 32 compact magnetic cylinders

Single and double-acting, non-rotating
 Ø 20, 25, 32, 40, 50, 63, 80, 100 mm

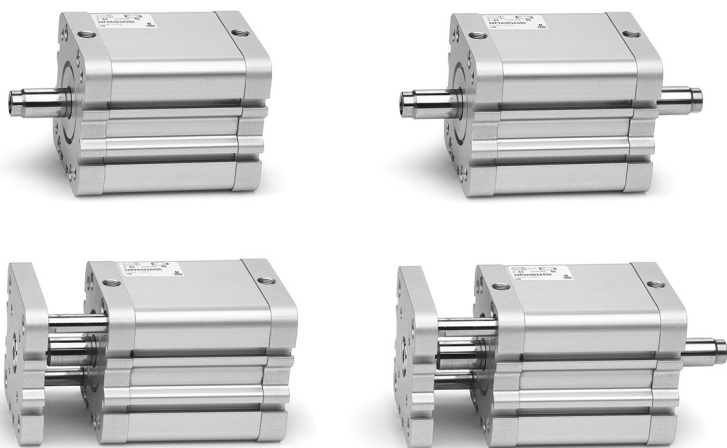

- » In compliance with ISO 21287
- » Compact design
- » Wide range of models available in different diameters



Series 32 cylinders, thanks to their compactness, are suitable for installation in confined spaces. Being in compliance with the ISO 21287 Standard, the cylinders Series 32 have the advantage that they can be used in conjunction with mountings/accessories suitable for other standard cylinders ISO15552.

GENERAL DATA

Construction	compact profile
Operation	single and double acting, magnetic
Design	ISO 21287
Materials	anodized AL body and end-blocks - rolled stainless steel AISI 303 rod anodized AL piston - rod seal, end-block OR and piston seal in PU high temperatures: rod seal, OR end-block and piston in FKM (140°)
Mounting	with threaded holes on the end blocks flange - feet - trunnion
Stroke min and max (1)	Series 32F, 32M, 32R Ø20-25 = 5-300 mm Series 32F, 32M, 32R Ø32-40-50-63 = 5-400 mm Series 32F, 32M, 32R Ø80-100 = 5-500 mm
Operating temperature	0°C ÷ 80°C (with dry air -20°C)
Operating pressure	1 ÷ 10 bar (double-acting) 2 ÷ 10 bar (single-acting)
Fluid	clean air without lubrication. If lubricated air is used it is recommended to use oil ISOVG32. Once applied the lubrication should never be interrupted.
Operation speed	10 ÷ 1000mm/sec. (without load)

(1) the minimum stroke for the use of the sensors is 10 mm.

STANDARD STROKES FOR CYLINDERS SERIES 32

✕ = Non-rotating ● = Double-acting, male/female rod thread;
■ = Single-acting, front/rear spring, male/female rod thread.

STANDARD STROKES										
∅	5	10	15	20	25	30	40	50	60	80
20	✕ ● ■	✕ ● ■	✕ ● ■	✕ ● ■	✕ ● ■	✕ ●	✕ ●	✕ ●		
25	✕ ● ■	✕ ● ■	✕ ● ■	✕ ● ■	✕ ● ■	✕ ●	✕ ●	✕ ●		
32	✕ ● ■	✕ ● ■	✕ ● ■	✕ ● ■	✕ ● ■	✕ ●	✕ ●	✕ ●	✕ ●	✕ ●
40	✕ ● ■	✕ ● ■	✕ ● ■	✕ ● ■	✕ ● ■	✕ ●	✕ ●	✕ ●	✕ ●	✕ ●
50		✕ ● ■	✕ ● ■	✕ ● ■	✕ ● ■	✕ ●	✕ ●	✕ ●	✕ ●	✕ ●
63		✕ ● ■	✕ ● ■	✕ ● ■	✕ ● ■	✕ ●	✕ ●	✕ ●	✕ ●	✕ ●
80		✕ ● ■	✕ ● ■	✕ ● ■	✕ ● ■	✕ ●	✕ ●	✕ ●	✕ ●	✕ ●
100		✕ ● ■	✕ ● ■	✕ ● ■	✕ ● ■	✕ ●	✕ ●	✕ ●	✕ ●	✕ ●

CODING EXAMPLE

32	M	2	A	032	A	050	
-----------	----------	----------	----------	------------	----------	------------	--

32	SERIES	
M	VERSION M = male rod thread, mounted with rod nut Mod. U F = female rod thread R = antirotation with flange (not for single-acting version)	
2	OPERATION 1 = single-acting, front spring 2 = double-acting 3 = double-acting, through-rod 4 = single-acting, rear spring	PNEUMATIC SYMBOLS CS06 CD08 CD12 CS08
A	MATERIALS A = anodized aluminium body, end blocks and piston, PU seals (rod, end-blocks OR and piston)	
032	BORES 020 = 20 mm - 025 = 25 mm - 032 = 32 mm - 040 = 40 mm 050 = 50 mm - 063 = 63 mm - 080 = 80 mm - 100 = 100 mm	
A	CONSTRUCTION A = standard	
050	STROKE (see the table) = standard V = FKM rod seal W = high temperatures (double-acting, non-magnetic with FKM seals for high temperatures up to 140°C)	

PNEUMATIC SYMBOLS

The pneumatic symbols which have been indicated in the CODING EXAMPLE are shown below.

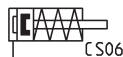
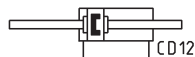
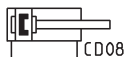

ACCESSORIES FOR CYLINDERS SERIES 32



Piston rod socket joint
Mod. GY



Piston rod lock nut
Mod. U



Clevis pin Mod. S



Rear trunnion ball-joint
Mod. R



Coupling piece
Mod. GKF



Swivel ball joint Mod. GA

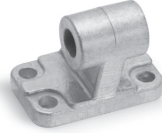

90° male trunnion
Mod. ZC



Swivel combination
Mod. C+L+S



Front and rear flange Mod.
D-E



Self aligning rod
Mod. GK



90° swivel combination
for trunnion Mod. I



Foot mount Mod. B



Front female trunnion
Mod. H and C-H



Rear female trunnion
Mod. C and C-H

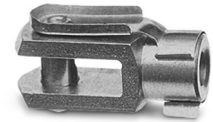

Rod fork end Mod. G



Rear trunnion male
Mod. L



Centring sleeve Mod. TR



All accessories are supplied separately.

APPLICABLE LOADS

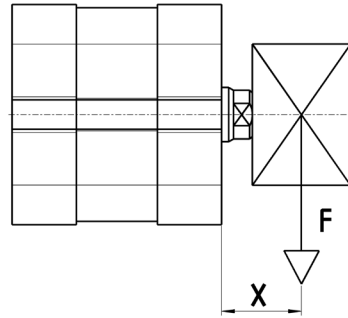
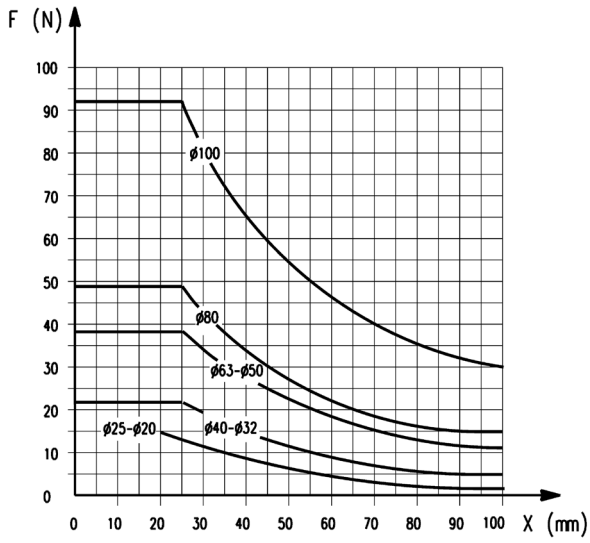

Standard.
Transversal load (F) dependant on stroke (X)

APPLICABLE LOADS

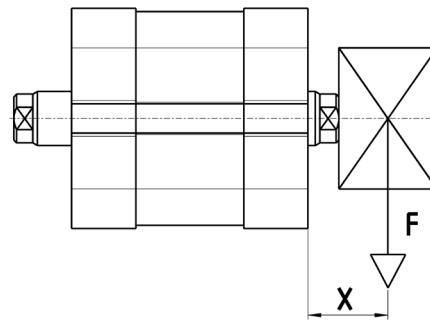
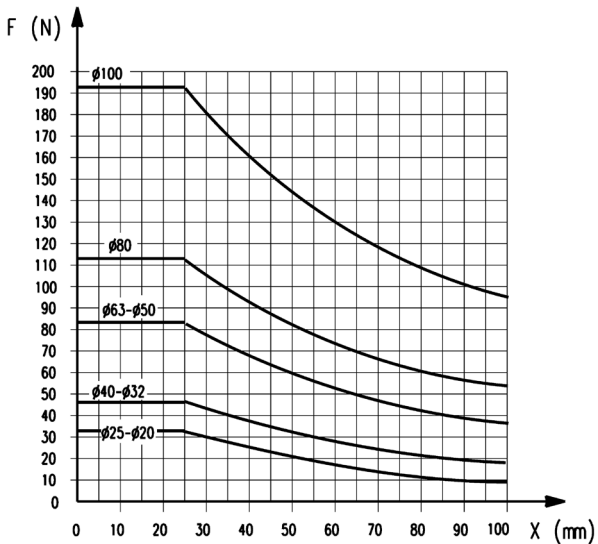

Through-rod.
Transversal load (F) dependant on stroke (X)

APPLICABLE LOADS

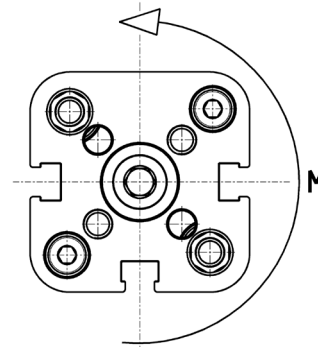
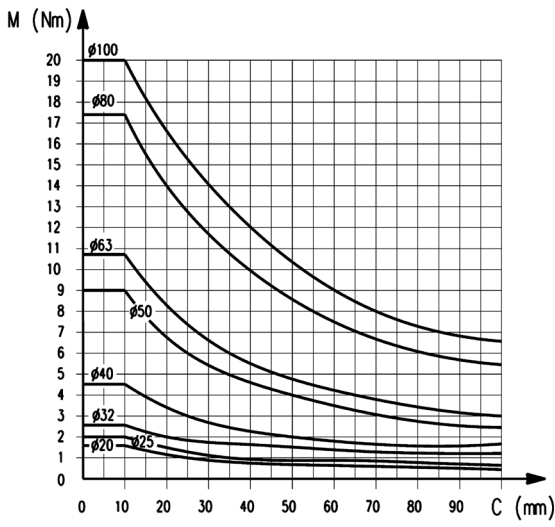

It is possible to use longer strokes as indicated in the general data (excluding radial loads and torque moments). When imposing radial loads on the cylinder it is important to respect the maximum stroke of the centre of gravity. In the presence of torque moments, respect the maximum stroke as shown in the diagrams.

Torque moment (M) dependant on stroke (C).

APPLICABLE LOADS

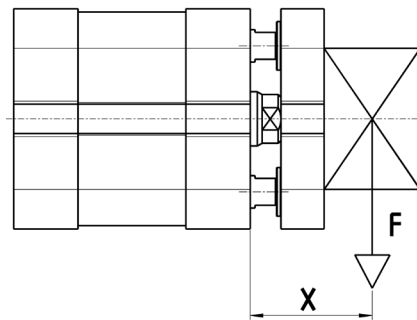
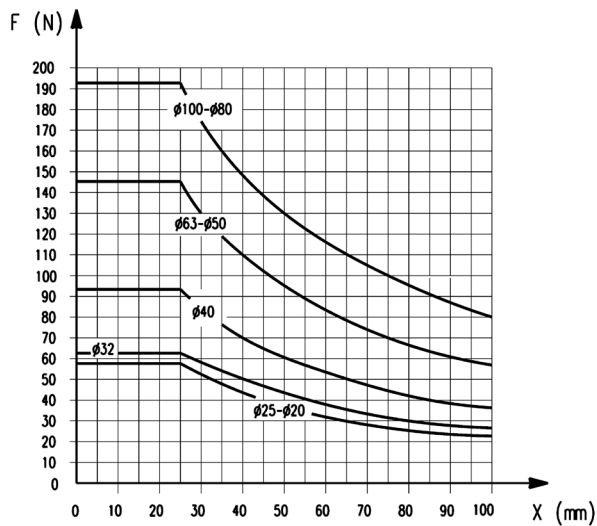

Anti-rotation.
Transversal load (F) dependant on stroke (X).

APPLICABLE LOADS

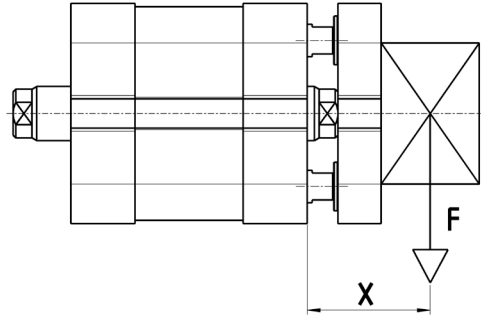
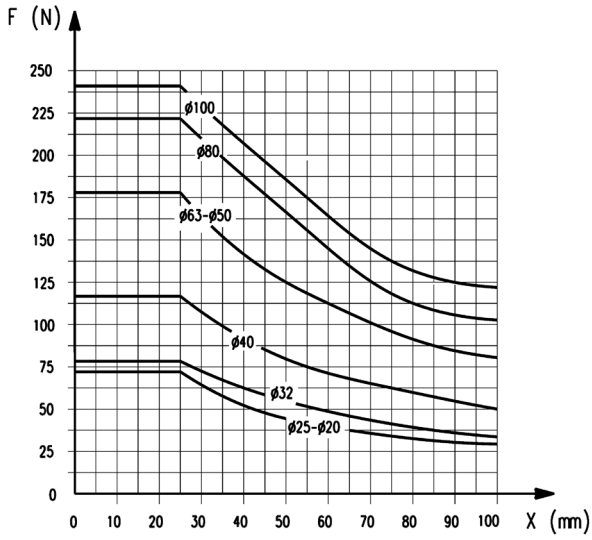

Anti-rotation through-rod.
Transversal load (F) dependant on stroke (X).

MOUNTING EXAMPLE

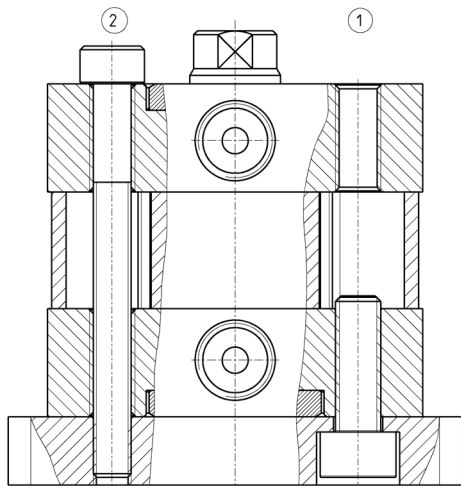

Mounting example for mounting cylinders \varnothing 32; 40; 50; 63; 80; 100.
1 = Rear mounting
2 = Through mounting

N.B. For through mounting with screws through the cylinder it is recommended to use non-magnetic screws.

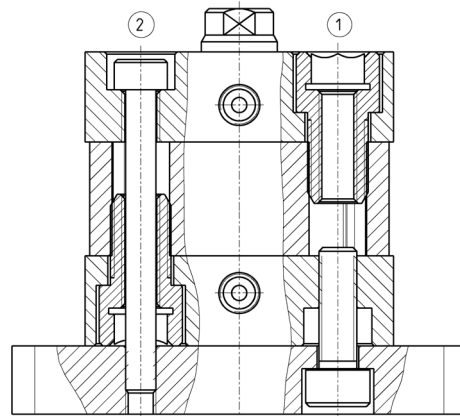

Mounting example for mounting cylinders \varnothing 20 ÷ 25.
1 = Rear mounting
2 = Through mounting

N.B. For through mounting with screws through the cylinder it is recommended to use non-magnetic screws.

Compact magnetic cylinders Mod. 32F and 32M



+ = add the stroke
1 = groove for sensor

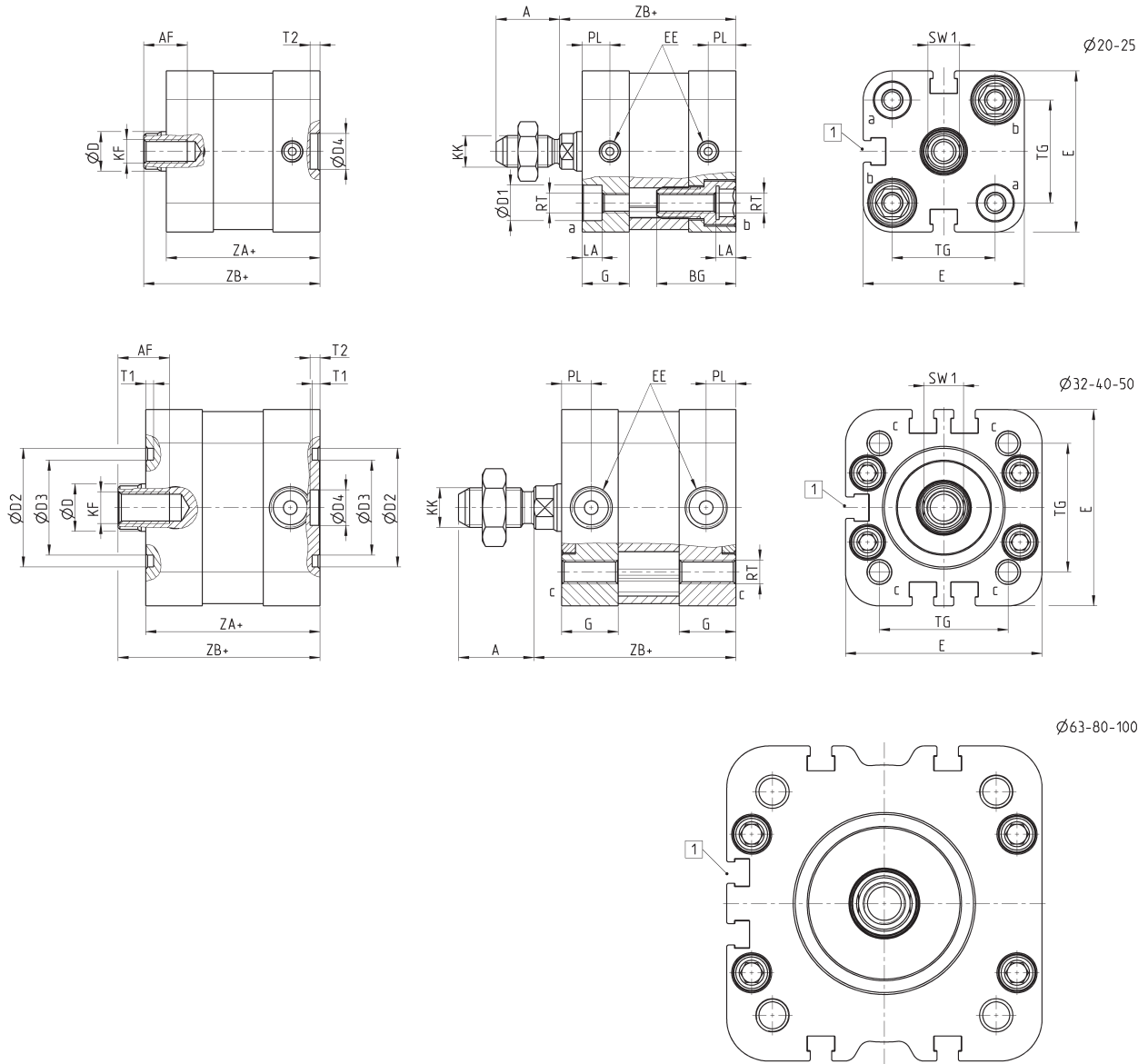

DIMENSIONS																						
Ø	A	AF	BG	G	ØD	D1	ØD2	ØD3	ØD4	E	EE	KF	KK	LA	PL	RT	SW1	T1	T2	TG	ZA	ZB
20	16	11	20	10,9	10	9	-	-	9	35,8	M5	M6	M8X1,25	5	6,5	M5	8	-	2,5	22	36,8	42,5
25	16	11	20	11,9	10	9	-	-	9	40,7	M5	M6	M8X1,25	5	7	M5	8	-	2,5	26	38,8	44,5
32	19	13	-	14,3	12	-	30	24	9	49,6	G1/8	M8	M10X1,25	-	7,6	M6	10	2	2,5	32,5	44	51
40	19	13	-	14,3	12	-	35	29	9	57	G1/8	M8	M10X1,25	-	7,6	M6	10	2	2,5	38	45	52
50	22	16	-	14,3	16	-	40	34	12	69,6	G1/8	M10	M12X1,25	-	7,6	M8	13	2	3	46,5	45	53
63	22	16	-	14	16	-	45	39	12	79,6	G1/8	M10	M12X1,25	-	7,6	M8	13	2	3	56,5	49	57
80	28	20	-	14,8	20	-	45	39	12	95,6	G1/8	M12	M16X1,5	-	7,7	M10	17	2	3	72	54	63,5
100	28	20	-	17,8	25	-	55	49	12	115,6	G1/8	M12	M16X1,5	-	8	M10	22	2	3	89	66,8	76,5

Products designed for industrial applications.
General terms and conditions for sale are available on www.camozzi.com.

Compact magnetic cylinders Mod. 32F3 and 32M3



+ = add the stroke once
++ = add the stroke twice
1 = groove for sensor

SERIES 32 CYLINDERS

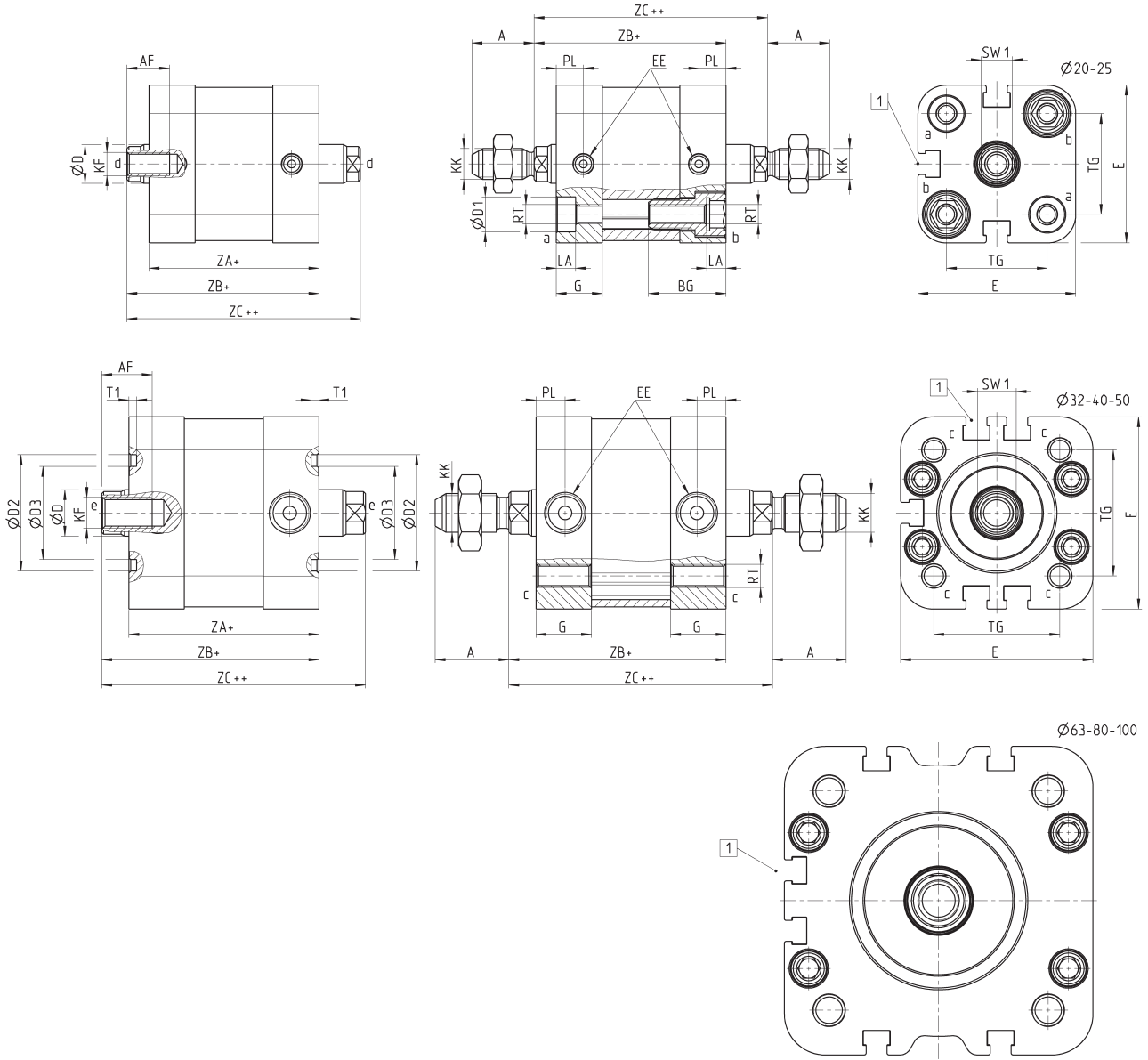

DIMENSIONS																					
Ø	A	AF	BG	G	ØD	ØD1	ØD2	ØD3	E	EE	KF	KK	LA	PL	RT	SW1	T1	TG	ZA	ZB	ZC
20	16	11	20	10,9	10	9	-	-	35,8	M5	M6	M8X1,25	5	6,5	M5	8	-	22	36,8	42,5	48,2
25	16	11	20	11,9	10	9	-	-	40,7	M5	M6	M8X1,25	5	7	M5	8	-	26	38,8	44,5	50,2
32	19	13	-	14,3	12	-	30	24	49,6	G1/8	M8	M10X1,25	-	7,6	M6	10	2	32,5	44	51	58
40	19	13	-	14,3	12	-	35	29	57	G1/8	M8	M10X1,25	-	7,6	M6	10	2	38	45	52	59
50	22	16	-	14,3	16	-	40	34	69,6	G1/8	M10	M12X1,25	-	7,6	M8	13	2	46,5	45	53	61
63	22	16	-	14	16	-	45	39	79,6	G1/8	M10	M12X1,25	-	7,6	M8	13	2	56,5	49	57	65
80	28	20	-	14,8	20	-	45	39	95,6	G1/8	M12	M16X1,5	-	7,7	M10	17	2	72	54	63,5	73
100	28	20	-	17,8	25	-	55	49	115,6	G1/8	M12	M16X1,5	-	8	M10	22	2	89	66,8	76,5	86,2

Compact magnetic cylinders Mod. 32R



+ = add the stroke once
 ++ = add the stroke twice
 1 = groove for sensor

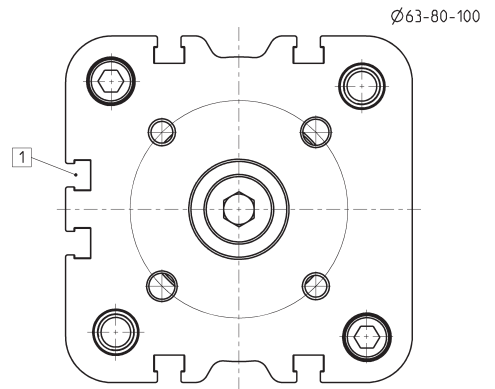
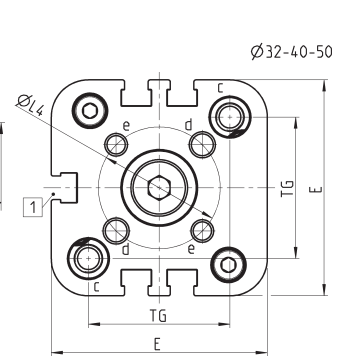
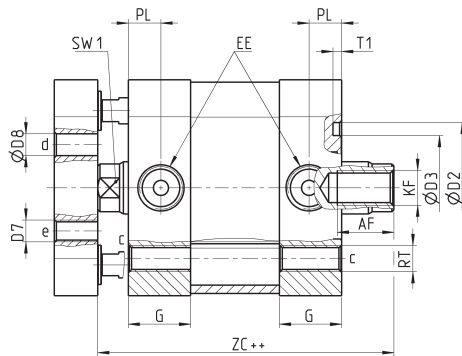
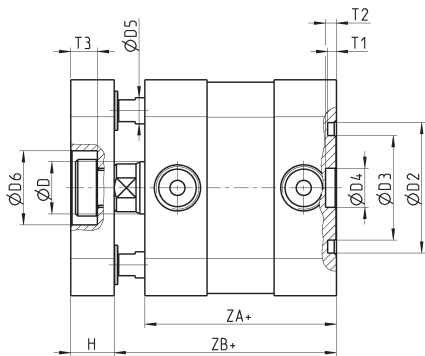
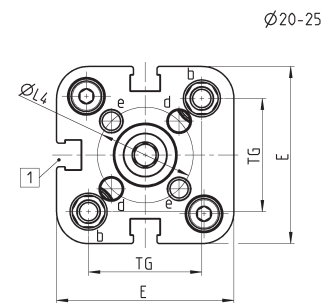
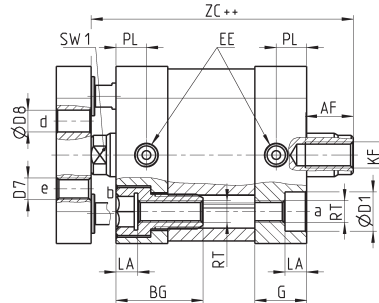
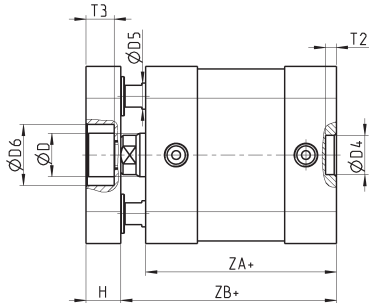

DIMENSIONS																												
Ø	AF	BG	G	ØD	ØD1	ØD2	ØD3	ØD4	ØD5	ØD6	D7	ØD8	E	EE	H	KF	LA	ØL4	PL	RT	SW1	T1	T2	T3	TG	ZA	ZB	ZC
20	11	20	10.9	10	9	-	-	9	6	-	M4	4	35.8	M5	8	M6	5	17	6.5	M5	8	-	2.5	-	22	36.8	42.5	48.2
25	11	20	11.9	10	9	-	-	9	6	14	M5	5	40.7	M5	8	M6	5	22	7	M5	8	-	2.5	6.5	26	38.8	44.5	50.2
32	13	-	14.3	12	-	30	24	9	6	17	M5	5	49.6	G1/8	10	M8	-	28	7.6	M6	10	2	2.5	6	32.5	44	51	58
40	13	-	14.3	12	-	35	29	9	6	17	M5	5	57	G1/8	10	M8	-	33	7.6	M6	10	2	2.5	6	38	45	52	59
50	16	-	14.3	16	-	40	34	12	10	22	M6	6	69.6	G1/8	12	M10	-	42	7.6	M8	13	2	3	7	46.5	45	53	61
63	16	-	14	16	-	45	39	12	10	22	M6	6	79.6	G1/8	12	M10	-	50	7.6	M8	13	2	3	7	56.5	49	57	65
80	20	-	14.8	20	-	45	39	12	12	24	M8	8	95.6	G1/8	14	M12	-	65	7.7	M10	17	2	3	10.5	72	54	63.5	73
100	20	-	18	25	-	55	49	12	12	24	M10	10	115.6	G1/8	14	M12	-	80	8	M10	22	2	3	10.5	89	67	76.7	86.2

Foot mount Mod. B

Material: zinc-plated steel.



Supplied with:
2x feet
4x screws
+ = add the stroke

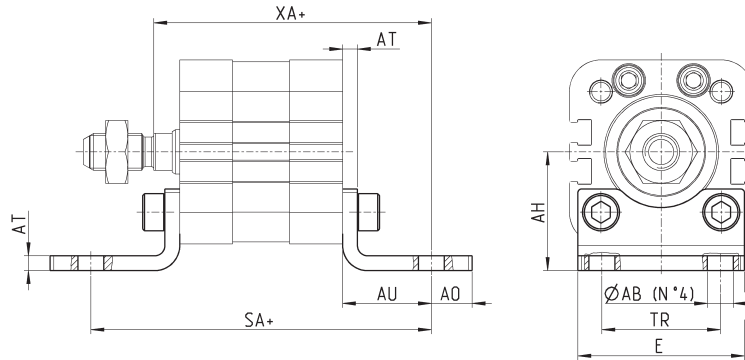

DIMENSIONS										
Mod.	∅	∅AB	AH	AO	AU	AT	E	TR	SA	XA
B-32-20	20	6,5	27	9	16	4	35	22	68,8	58,5
B-31-25	25	6,5	29	9	16	4	39	26	70,8	60,5
B-41-32	32	7	32	11	24	4	45	32	92	75
B-41-40	40	10	36	15	28	4	53,5	36	101	80
B-41-50	50	10	45	15	32	4	62,5	45	109	85
B-41-63	63	10	50	15	32	5	73	50	113	89
B-41-80	80	12	63	20	41	6	92	63	136	104,5
B-41-100	100	14,5	71	25	41	6	108,5	71	148,8	117,5

Rear female trunnion Mod. C and C-H

Material: Aluminium.



Supplied with:
1x female trunnion
4x screws
+ = add the stroke

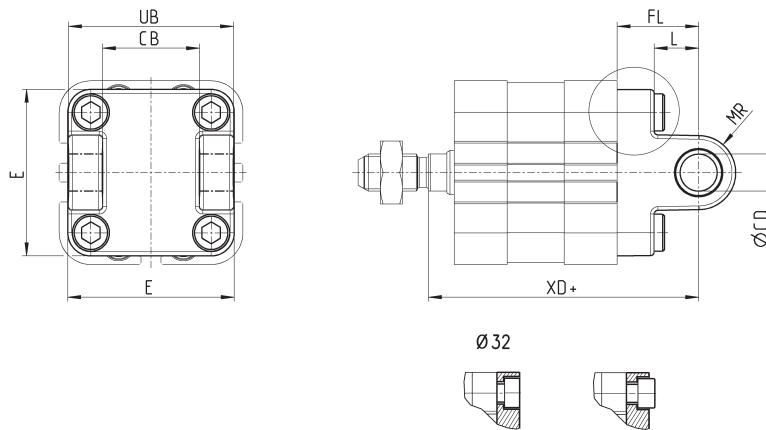

DIMENSIONS									
Mod.	∅	∅CD	E	CB	UB	L	FL	MR	XD+
C-41-32	32	10	47	26	46.5	12.5	22	10	73
C-41-40	40	12	52	28	52	16	25	12	77
C-41-50	50	12	64	32	60	16	27	12	80
C-H-41-63	63	16	74	40	70	21	32	16	89
C-H-41-80	80	16	94	50	90	22	36	16	99,5
C-H-41-100	100	20	114	60	110	27	41	20	117,5

Front female trunnion Mod. H and C-H

Material: Aluminium.



Supplied with:
1x female trunnion
4x screws

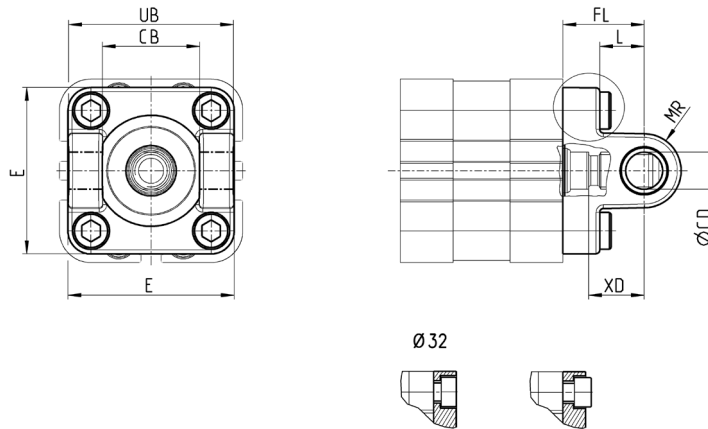

DIMENSIONS									
Mod.	Ø	ØCD	E	CB	UB	L	FL	MR	XD
H-41-32	32	10	47	26	46.5	12.5	22	10	15
H-41-40	40	12	52	28	52	16	25	12	18
H-41-50	50	12	64	32	60	16	27	12	19
H-60-63	63	16	74	40	70	21	32	16	24
C-H-41-80	80	16	94	50	90	22	36	16	26,5
C-H-41-100	100	20	114	60	110	27	41	20	31,3

Front and rear flange Mod. D-E

Material: zinc-plated steel for Ø 20 - Ø 25; Aluminium for Ø 32 ÷ Ø 100.



Supplied with:
1x flange
4x screws

+ = add the stroke

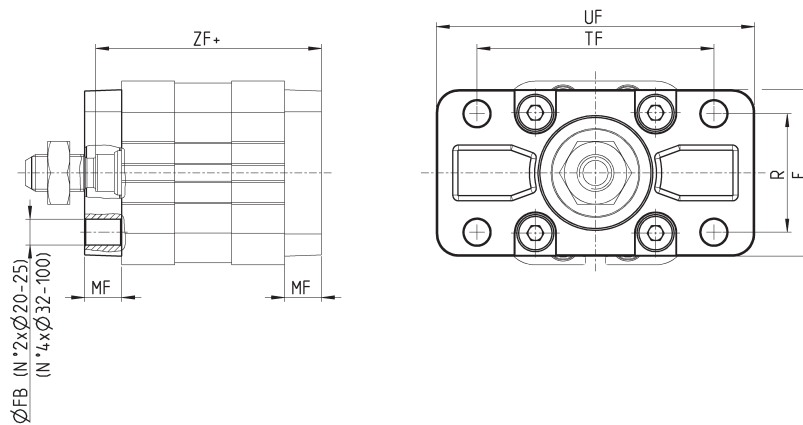

DIMENSIONS								
Mod.	Ø	ØFB	E	MF	R	TF	UF	ZF+
D-E-32-20	20	6,6	36	10	-	55	70	52,5
D-E-32-25	25	6,6	40	10	-	60	76	54,5
D-E-41-32	32	7	45	10	32	64	80	61
D-E-41-40	40	9	52	10	36	72	90	62
D-E-41-50	50	9	65	12	45	90	110	65
D-E-41-63	63	9	75	12	50	100	120	69
D-E-41-80	80	12	95	16	63	126	150	79,5
D-E-41-100	100	14	115	16	75	150	170	92,5

Rear trunnion male Mod. L

Material: Aluminium.

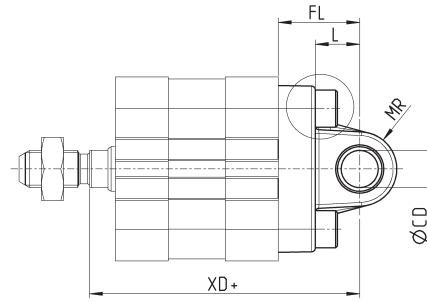
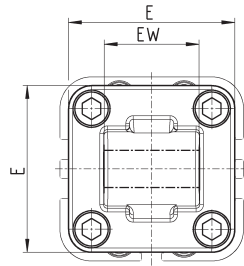

Supplied with:
1x male trunnion
4x screws

+ = add the stroke

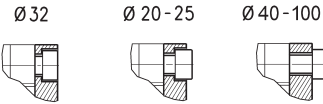

DIMENSIONS								
Mod.	Ø	Ø _{CD}	E	EW	L	FL	MR	XD+
L-32-20	20	8	34	16	14	20	8	62,5
L-32-25	25	8	38	16	14	20	8	64,5
L-41-32	32	10	47	26	12.5	22	10	73
L-41-40	40	12	52	28	16	25	12	77
L-41-50	50	16	64	32	16	27	12	80
L-41-63	63	16	74	40	21	32	15.5	89
L-41-80	80	20	94	50	22	36	16	99,5
L-41-100	100	20	114	60	27	41	20	117,5

Rear trunnion ball-joint Mod. R

* This trunnion doesn't comply with the ISO 15552 standard
Material: Aluminium

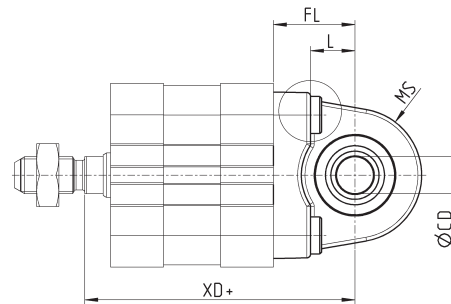
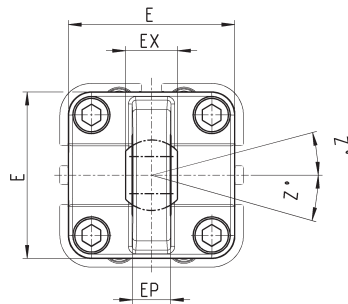

Supplied with:
1x ball joint
4x screws

+ = add the stroke

R-41-50/80

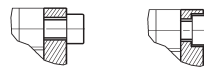

DIMENSIONS										
Mod.	Ø	Ø _{CD}	E	EX	EP	L	FL	MS	XD+	Z°
R-41-32	32	10	45	14	10.5	12	22	16	73	4
R-41-40	40	12	52	16	12	15	25	19	77	4
R-41-50*	50	12	62.5	16	12	15	27	21	80	4
R-50	50	16	65	21	15	16	27	21.5	80	4
R-41-63	63	16	75	21	15	20	32	24	89	4
R-41-80*	80	16	92	21	15	24	36	28	99,5	4
R-80	80	20	95	25	18	22	36	28.5	99,5	4
R-41-100	100	20	115	27	18	25	41	30	117.5	4

Accessory combination Mod. C+L+S

Material: Aluminium.

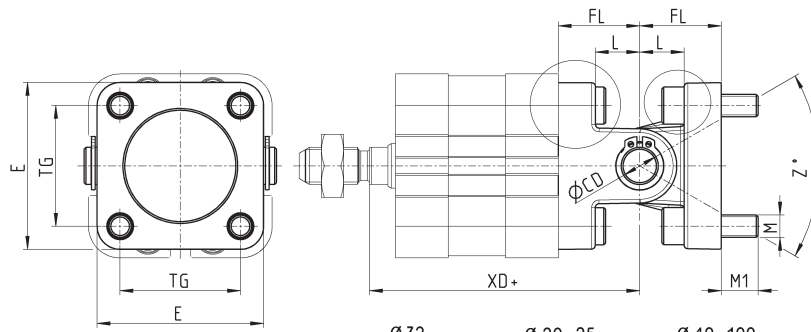
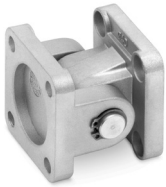

+ = add the stroke

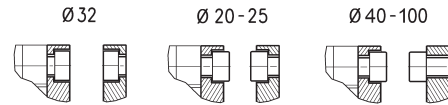

DIMENSIONS										
Mod.	Ø	ØCD	E	L	FL	M	M1	TG	XD+	Z° (max)
C+L+S	32	10	47	12.5	22	M6	10.5	32.5	73	30
C+L+S	40	12	52	16	25	M6	10.5	38	77	40
C+L+S	50	12	64	16	27	M8	11.5	46.5	80	25
C+L+S	63	16	74	21	32	M8	13.5	56.5	89	36
C+L+S	80	16	93	22	36	M10	15	72	99.5	34
C+L+S	100	20	114	27	41	M10	15	89	117.5	38

90° male trunnion Mod. ZC

Material: Aluminium.

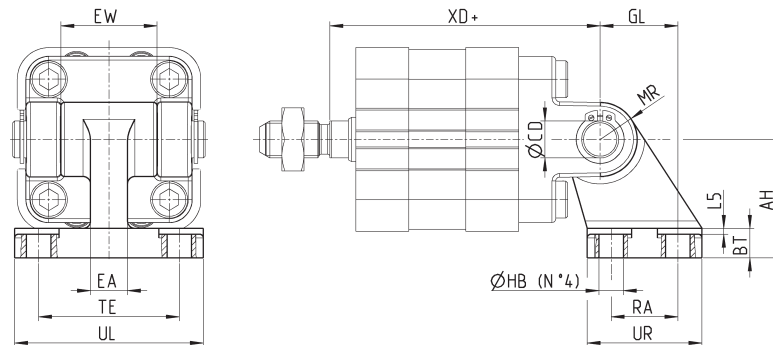
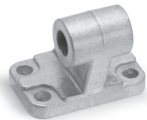

Supplied with:
1x male support

+ = add the stroke

DIMENSIONS															
Mod.	Ø	AH	BT	ØCD	EA	EW	GL	ØHB	L5	MR	RA	UL	UR	TE	XD
ZC-32	32	32	8	10	10	26	21	6,6	1,6	10	18	51	31	38	73
ZC-40	40	36	10	12	15	28	24	6,6	1,6	11	22	54	35	41	77
ZC-50	50	45	12	12	16	32	33	9	1,6	13	30	65	45	50	80
ZC-63	63	50	14	16	16	40	37	9	1,6	15	35	67	50	52	89
ZC-80	80	63	14	16	20	50	47	11	2,5	15	40	86	60	66	99,5
ZC-100	100	71	17	20	20	60	55	11	2,5	19	50	96	70	76	117,5

90° swivel combination for trunnion Mod. I

Material: zinc-plated steel.

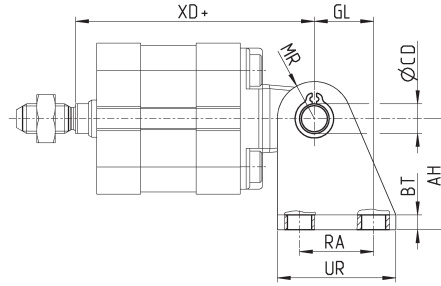
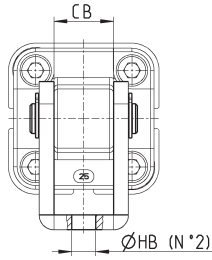

Supplied with:
1x female support
2x seeger
1x clevis pin

+ = add the stroke

SERIES 32 CYLINDERS

DIMENSIONS											
Mod.	∅	AT	BT	∅CD	CB	GL	∅HB	MR	RA	UR	XD
I-20-25	20	30	4	8	16,1	16	6,5	10	20	32	62,5
I-20-25	25	30	4	8	16,1	16	6,5	10	20	32	64,5

Clevis pin Mod. S

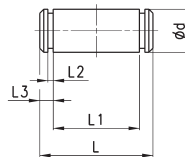

Supplied with:
1x clevis pin in stainless steel
2x Seeger in steel

DIMENSIONS						
Mod.	∅	D	L	L1	L2	L3
S-32	32	10	52	46	1,1	3
S-40	40	12	59	53	1,1	3
S-50	50	12	67	61	1,1	3
S-63	63	16	77	71	1,1	3
S-80	80	16	97	91	1,1	3
S-100	100	20	121	111	1,3	5

Rod fork end Mod. G

ISO 8140
Material: zinc-plated steel.

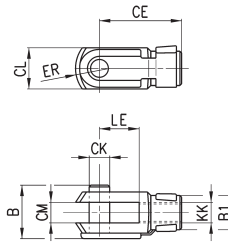
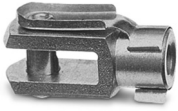

DIMENSIONS										
Mod.	∅	∅ _{CK}	LE	CM	CL	ER	CE	KK	B	∅ _{B1}
G-20	20-25	8	16	8	16	10	32	M8X1,25	22	14
G-25-32	32-40	10	20	10	20	12	40	M10x1,25	26	18
G-40	50-63	12	24	12	24	14	48	M12x1,25	32	20
G-50-63	80-100	16	32	16	32	19	64	M16x1,5	40	26

Piston rod socket joint Mod. GY

Material: zama and zinc-plated steel.

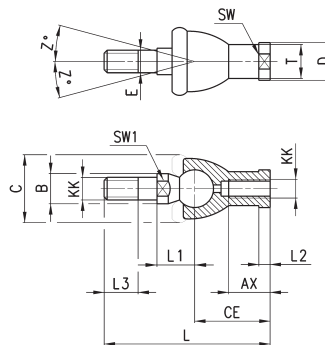

DIMENSIONS																	
Mod.	∅	KK	L	CE	L2	AX	SW	SW1	L1	L3	∅ _T	∅ _D	E	∅ _B	∅ _C	Z	
GY-20	20-25	M8X1,25	65	32	5	16	14	10	16	12	12,5	13	6	10	20	15	
GY-32	32-40	M10X1,25	74	35	6,5	18	17	11	19,5	15	15	19	10	14	28	15	
GY-40	50-63	M12X1,25	84	40	6,5	20	19	17	21	17	17,5	22	12	19	32	15	
GY-50-63	80-100	M16X1,5	112	50	8	27	22	19	27,5	23	22	27	16	22	40	11	

Piston rod lock nut Mod. U



ISO 4035
Materials: zinc-plated steel.

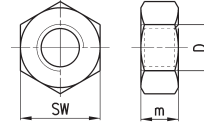

DIMENSIONS				
Mod.	∅	D	M	SW
U-20	20-25	M8X1,25	5	13
U-25-32	32-40	M10X1,25	6	17
U-40	50-63	M12X1,25	7	19
U-50-63	80-100	M16X1,5	8	24

Centring sleeve Mod. TR



Supplied with:
1x anodized AL centring ring

Designed for the centring of both rear and front end caps with brackets Mod. B/D-E/C/C-H/H/L/R, as for the centring of the cylinder while mounting.

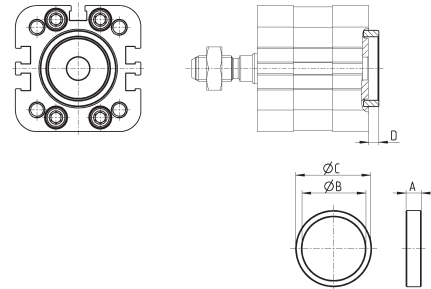

DIMENSIONS					
Mod.	∅	A	∅B	∅C	D
TR-32-32	32	6	25	30	4
TR-32-40	40	6	30	35	4
TR-32-50	50	6	35	40	4
TR-32-63	63-80	7	40	45	5
TR-32-100	100	7	50	55	5

Centring pin Mod. TS-32-20

Material: anodized AL

Designed for the centring of rear end caps with brackets L-32-20 / L-32-25 as for cylinder while mounting, it is also suitable in "a" holes of rear/front end caps of cyl. ∅20-25 or in the central hole of rear end caps of cyl. ∅32-40.

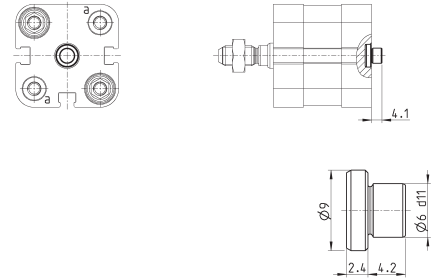

Mod.	TS-32-20
------	----------

Self aligning rod Mod. GK

Only for cylinders with male rod.

Material: zinc-plated steel.

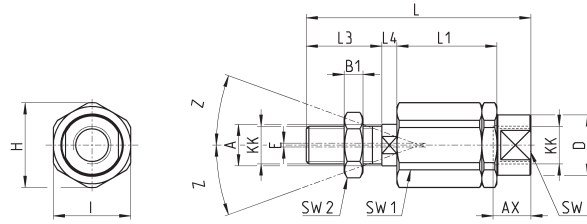

DIMENSIONS																	
Mod.	∅	KK	L	L1	L3	L4	∅A	∅D	H	I	SW	SW1	SW2	B1	AX	Z	E
GK-20	20-25	M8x1,25	57	26	21	5	8	12,5	19	17	11	7	13	4	16	4	2
GK-25-32	32-40	M10x1,25	71,5	35	20	7,5	14	22	32	30	19	12	17	5	22	4	2
GK-40	50-63	M12x1,25	75,5	35	24	7,5	14	22	32	30	19	12	19	6	22	4	2
GK-50-63	80-100	M16x1,5	104	53	32	10	22	32	45	41	27	20	24	8	30	3	2

Coupling piece Mod. GKF

Material: zinc-plated steel.

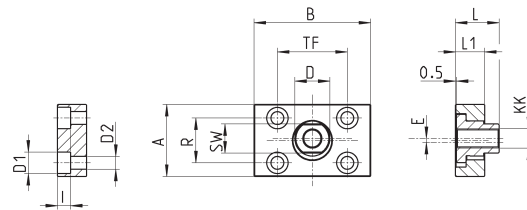

DIMENSIONS															
Mod.	∅	KK	A	B	R	TF	L	L1	I	∅D	∅D1	∅D2	SW	E	
GKF-20	20-25	M8x1,25	30	35	20	25	22,5	10	-	14	5,5	-	13	1,5	
GKF-25-32	32-40	M10x1,25	37	60	23	36	22,5	15	6,8	18	11	6,6	15	2	
GKF-40	50-63	M12x1,25	56	60	38	42	22,5	15	9	20	15	9	15	2,5	
GKF-50-63	80-100	M16x1,5	80	80	58	58	26,5	15	10,5	25	18	11	22	2,5	